

| | | |
|--|--|--|
| | | |
| | | |
| | | |



F



F

F

F

F

F

F

F

F

F

F

F

■





-
-
-
-
-

F

| | |
|--|---|
| | |
| | |
| | F |
| | |

F

F

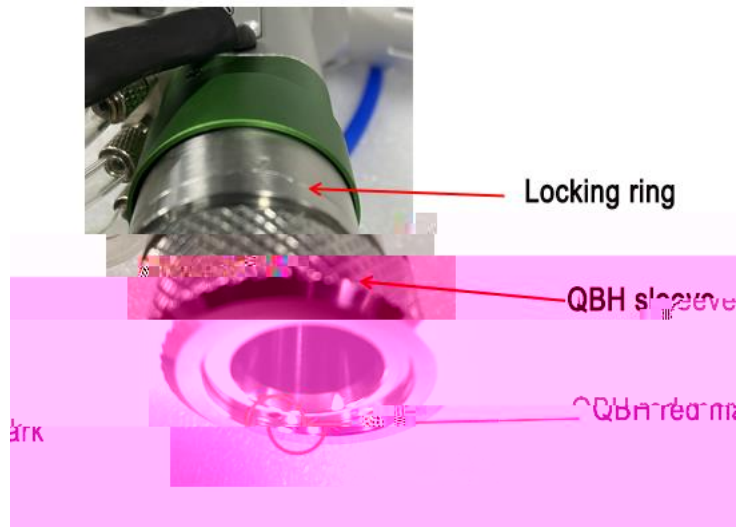
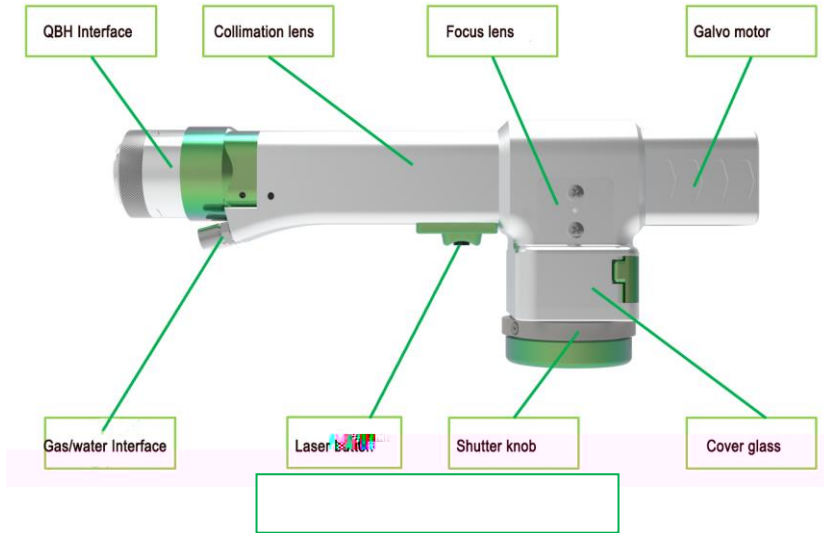

2

Fiber output head (QBH)



F

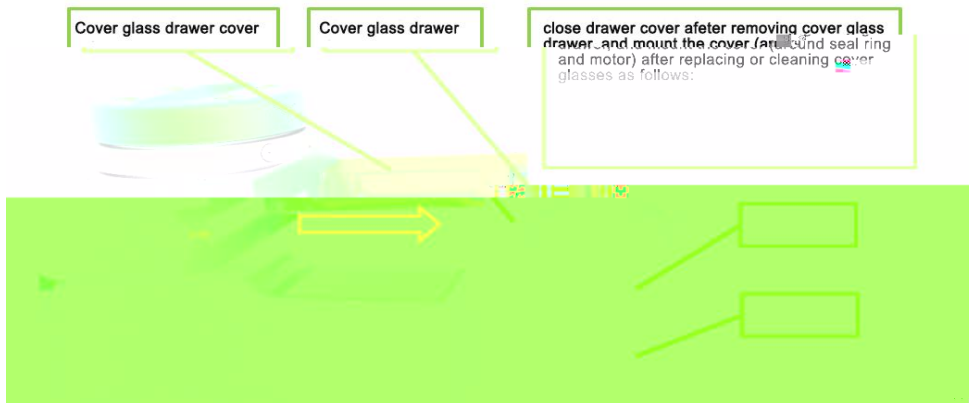
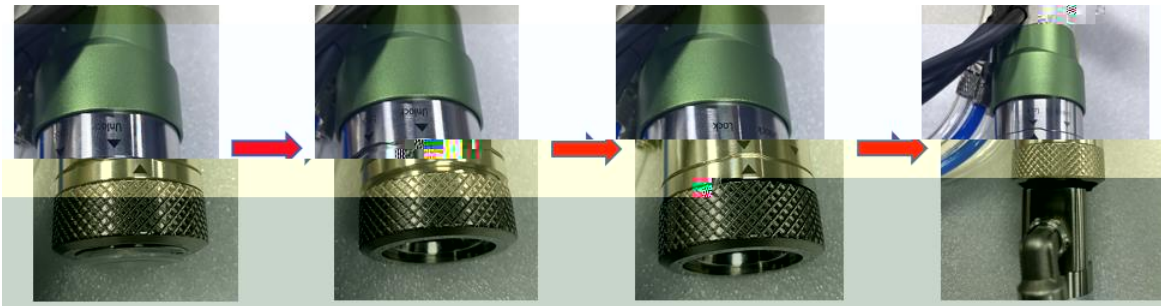

F

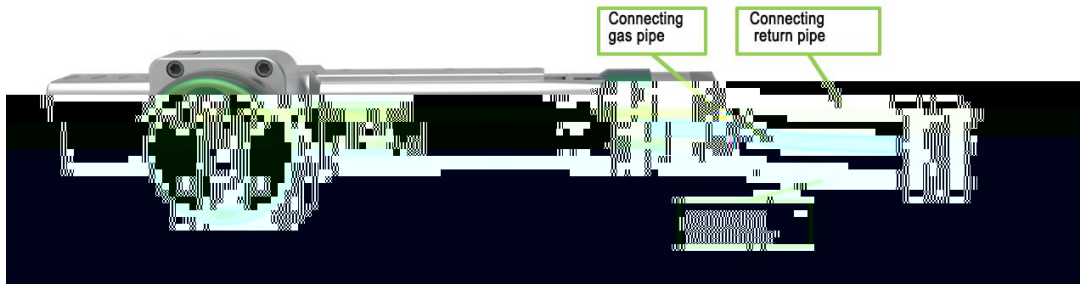

F

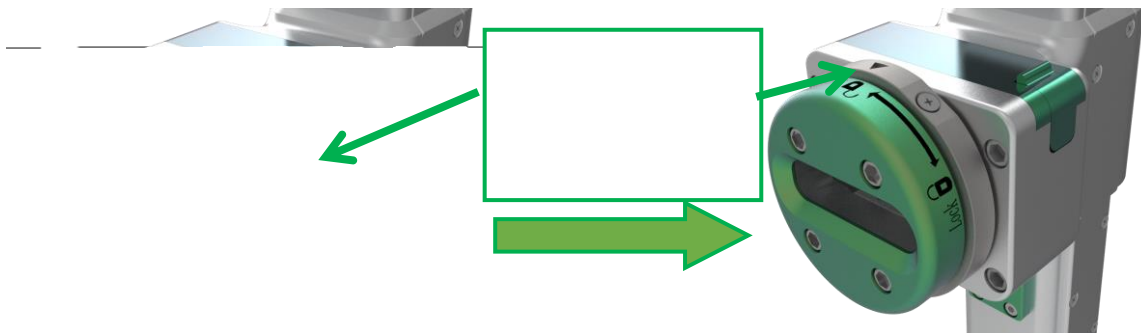

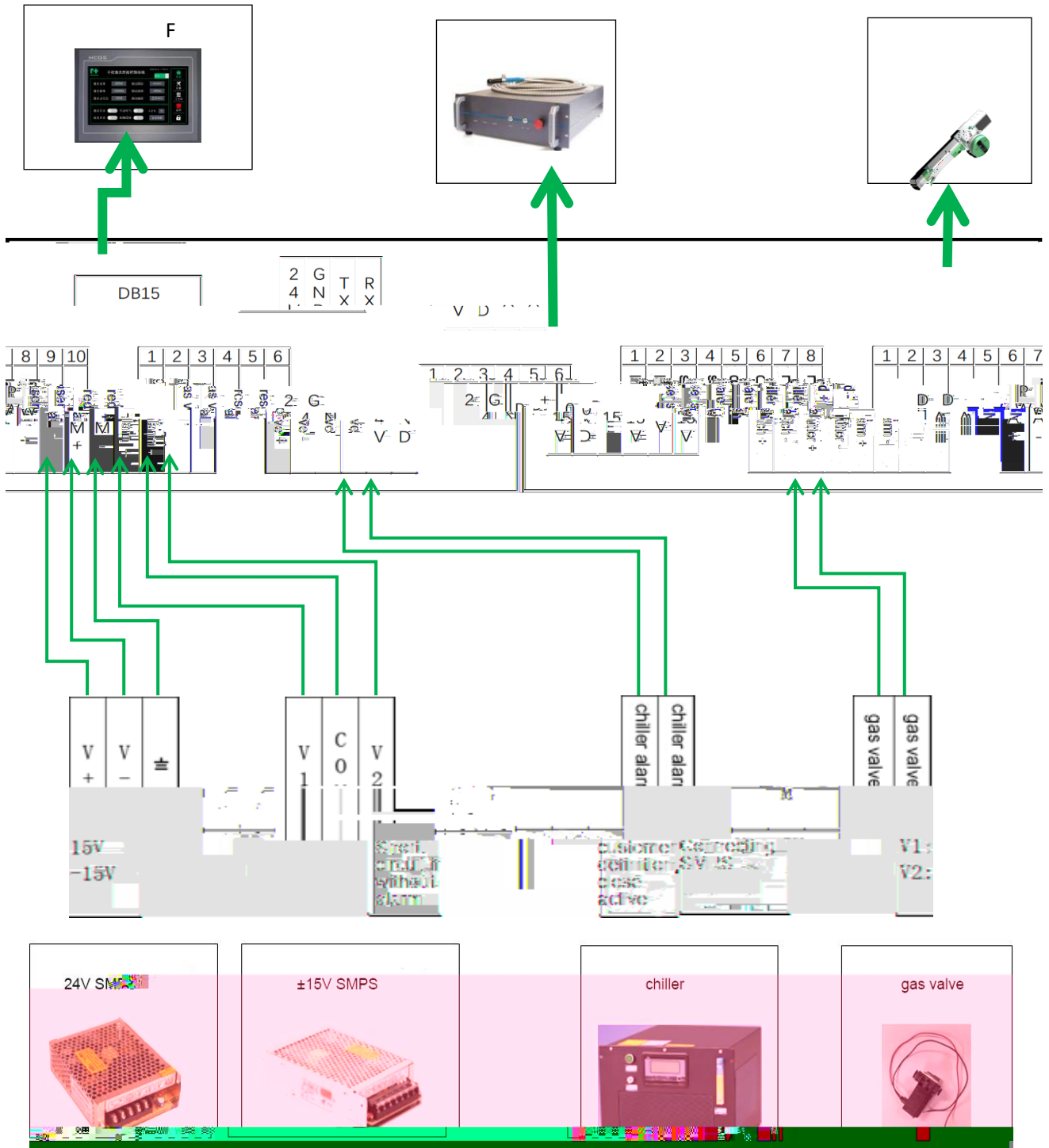



± F ± ±

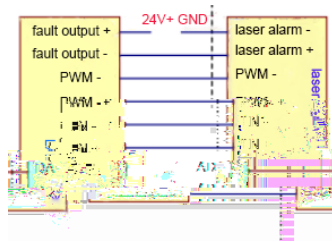

±
F
F ± F

F

±
±



±

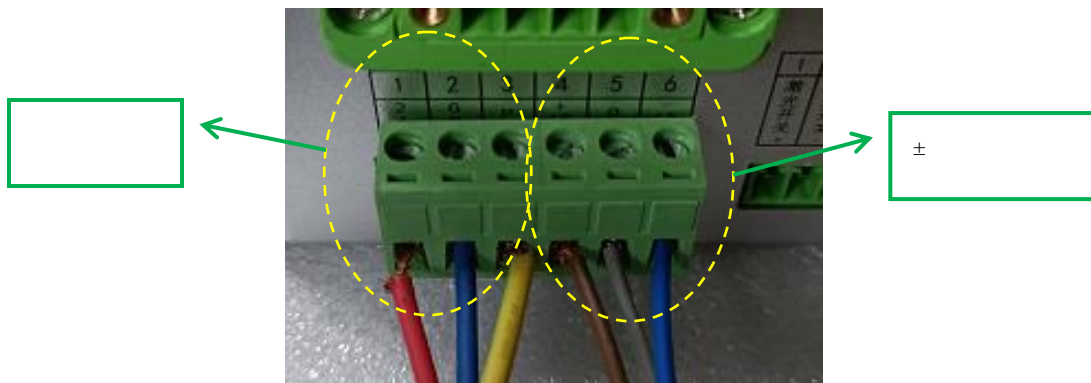

± F
F

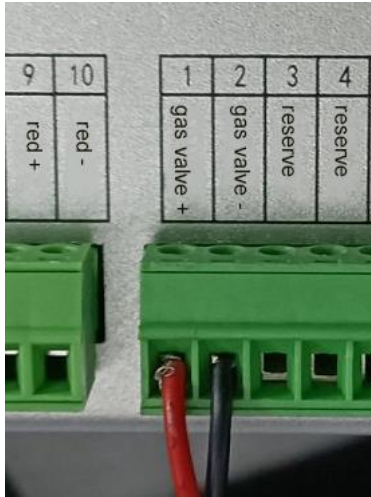

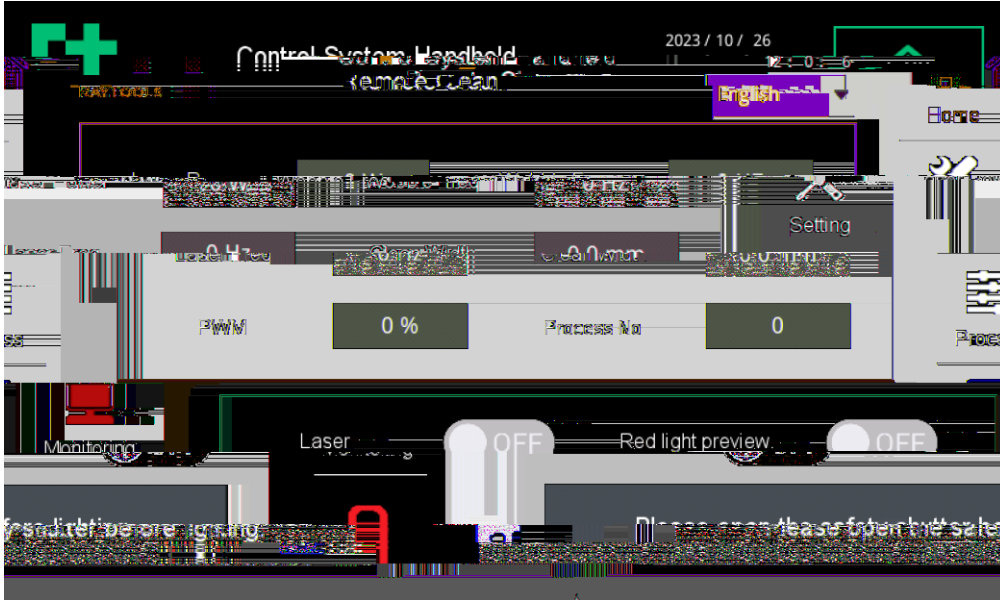

Laser Power

F

Laser Freq

PWM

F

Wobble Free

Clean Width

Laser

Red light preview

Process No

F

F

Please read the safety sheet before using the device.

F

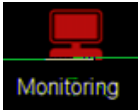
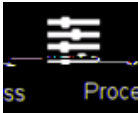

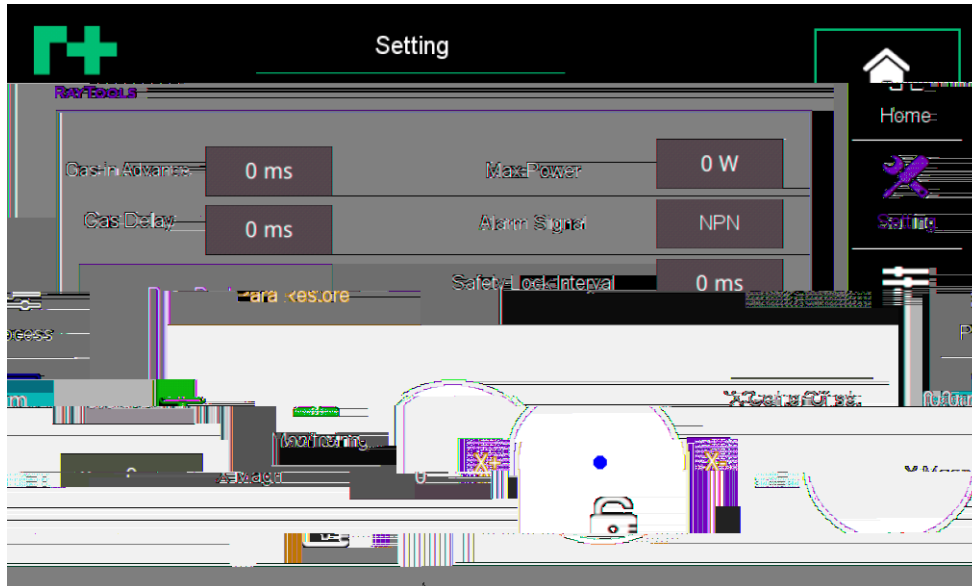

Gas in Advance

Gas Delay

Max Power

F

Alarm Signal

F

Safety Lock Interval

X Magn

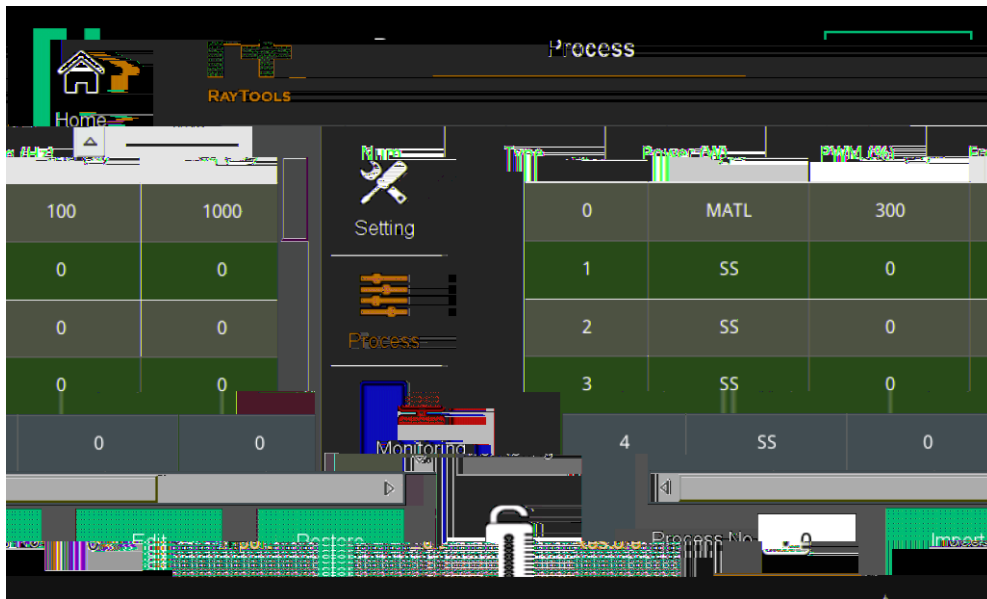

F F

Process No F

Import

Edit

Restore

F F

F

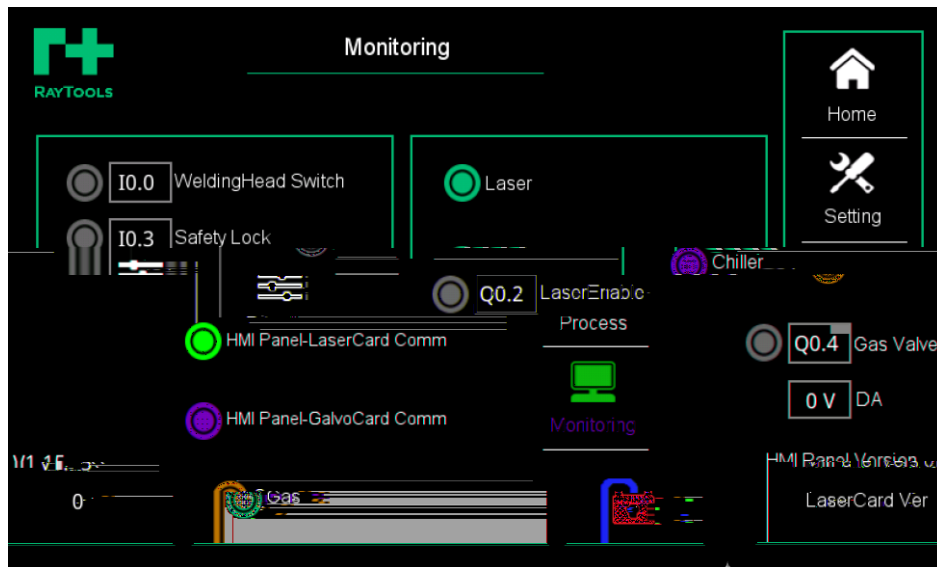

F



F



F

| | | |
|---|--|---|
| F | | |
| | | |
| | | |
| | | |
| | | F |
| | | |
| | | |
| | | |
| | | |
| | | |
| | | |

| | | | | | | | | |
|---|--|--|---|---|--|--|--|--|
| F | | | | | | | | |
| | | | | | | | | |
| | | | | | | | | |
| | | | | | | | | |
| | | | | | | | | |
| | | | F | F | | | | |
| | | | | | | | | |
| | | | | | | | | |
| | | | | | | | | |
| | | | | | | | | |
| | | | | | | | | |
| | | | | | | | | |
| | | | | | | | | |
| | | | | | | | | |
| | | | | | | | | |

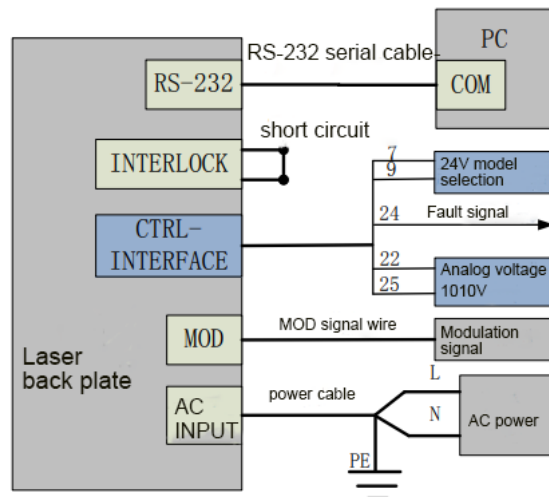

Figure 22 Wiring diagram in AD mode

